

# CIRCULAR PALLETIZER ROBOT

## RPAL360

RPAL360 is a four electronic axes circular robot, composed of the rotary base made by a fifth wheel allow the rotation of main column, able to reach through the longitudinal arm any point inside the pallet shape. The robot can manage multiple palletizing or depalletizing lines (up to 3) and introduce at format request an intermediate carton for divide each new layer from the previous (using any of the 3-pallet station as intermediate cartons buffer).

The gripper on the robot head may picking simultaneously single or multiple products, depending on the layout exigences of the pallet.

The palletizing sequence (including the management of the different angle of the product, the alternation between product or intermediate carton picking and the number of products to be picked up at the same time) is managed by an HMI operator panel 15 Inches Touchscreen, through the creation of recipes containing palletizing schemes.

The RPAL360 circular robot can be integrated into complete production lines, belonging to any market sector (Coffee, pet food food, cosmetics, pharmaceutical).

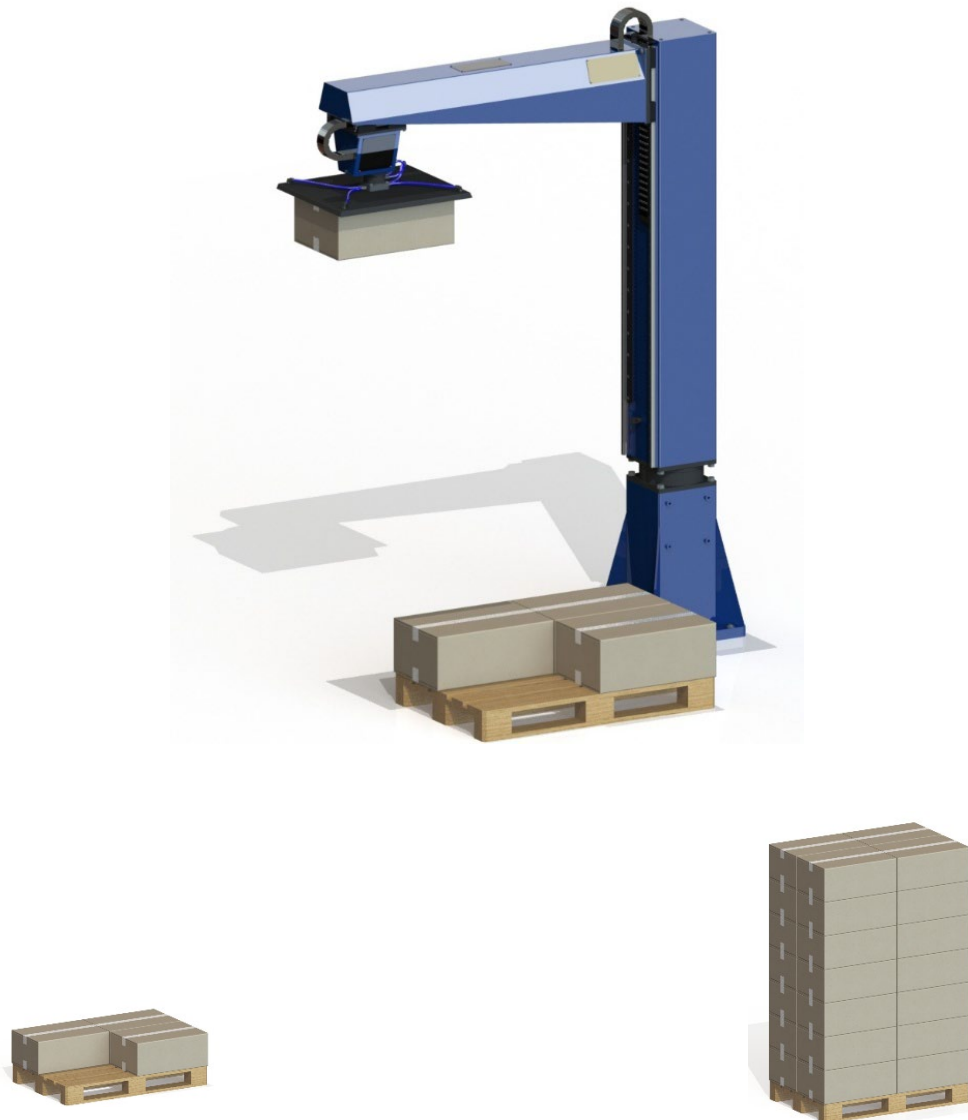

**TECHNICAL DATA:**

MACHINE SPEED: 8 RPM

PRODUCTION SPEED:  
 • Up to 16 Box/min

HUMAN INTERFACE: 15 Inches Touchscreen

OPTIONAL GROUPS:  
 • Intermediate carton layer buffer

AIR PRESSURE: 6 bar  
 AIR CONSUMPTION: < 150 NI/min  
 POWER INTALLED: 4 Kw  
 SUPPLY VOLTAGE: 400Vac + N - 50Hz  
 MACHINE WEIGHT: 450 Kg  
 PRODUCT WEIGHT: up to 60 Kg

**MACHINE FORMAT RANGE:**

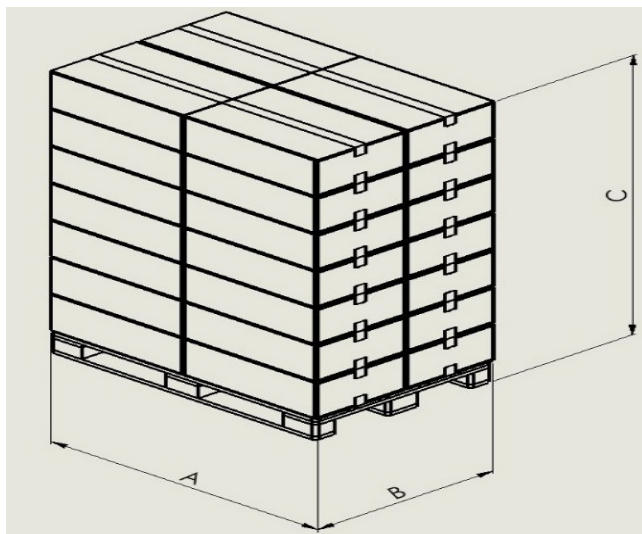

SIZE (mm)			
	A	B	C
Min	1200	800	100
	A	B	C
Max	1200	800	2200

**MACHINE LAYOUT:**

